

# Redevelopment of Surrey County Hall and the Bittoms Car Park

November 2020

## Heritage

**A full and detailed assessment of the listed county hall is being undertaken to inform its conversion and avoid or minimise adverse impacts. Similarly, the setting of all designated heritage assets potentially affected has been assessed and is informing the proposed massing and siting of the proposed development.**

A key heritage risk is to secure the long-term sustainable future for this significant heritage asset in the heart of Kingston. As previously announced, Surrey County Council will be vacating and leaving the site in December this year. The longer a building of this age and status stands empty the higher the risk.

## Response to Historic England

These proposals have been developed in continued close consultation with Historic England who commented as follows:

“We would encourage the retention and adaption of the 1963 building and an alternative design approach be pursued for the northern most range.”

In response the team have developed a revised proposal that retains and adapts the 1963 wing and maintains the building’s figure eight form by replacing the 1983 building with a contextually sensitive new element. This offers improvement to the setting of the 1893 building.

The adjacent diagrams show how the team have evaluated these concerns and developed a revised proposal that adapts the 1963 wing as well as maintains the figure eight overall form.

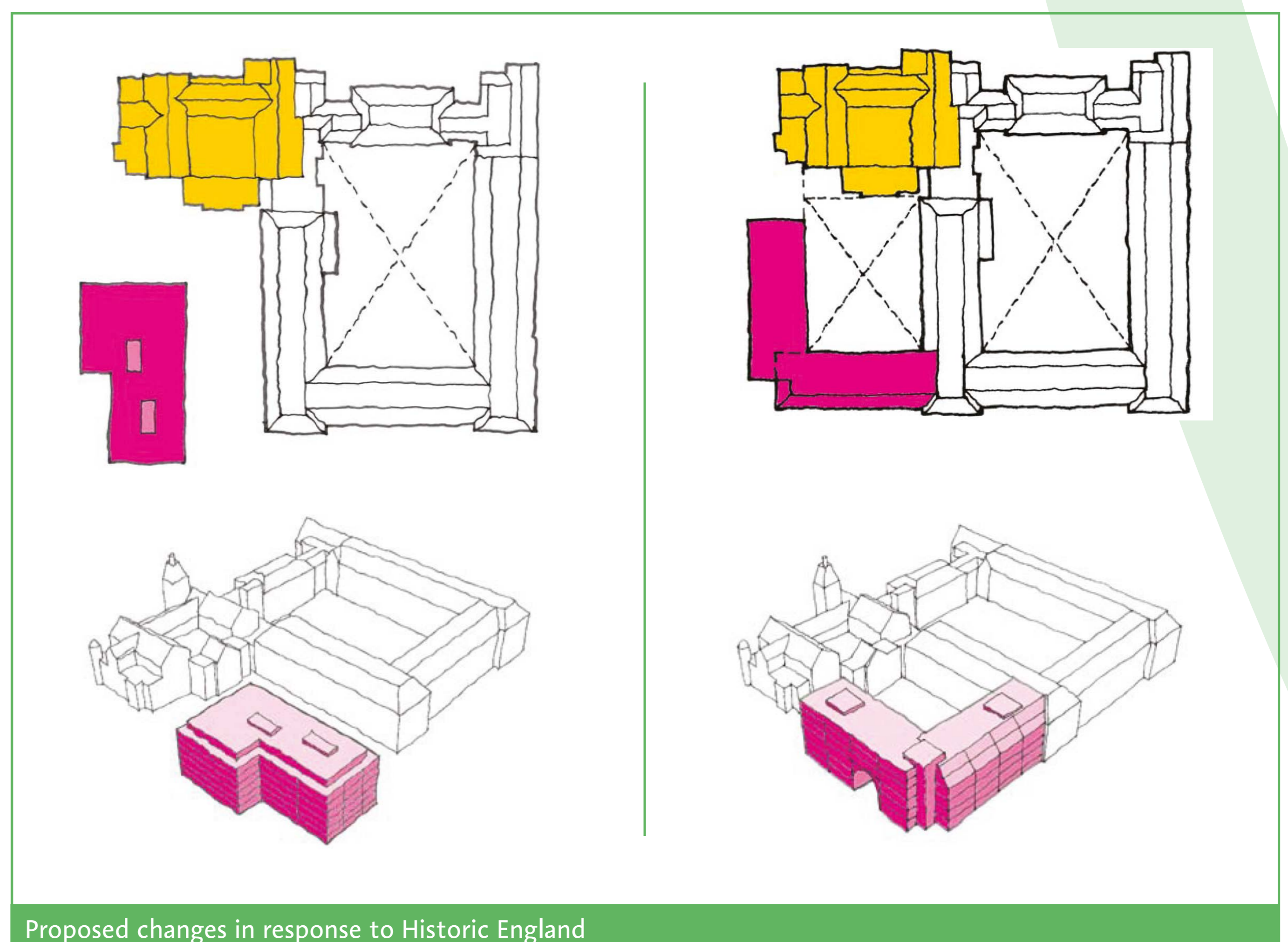
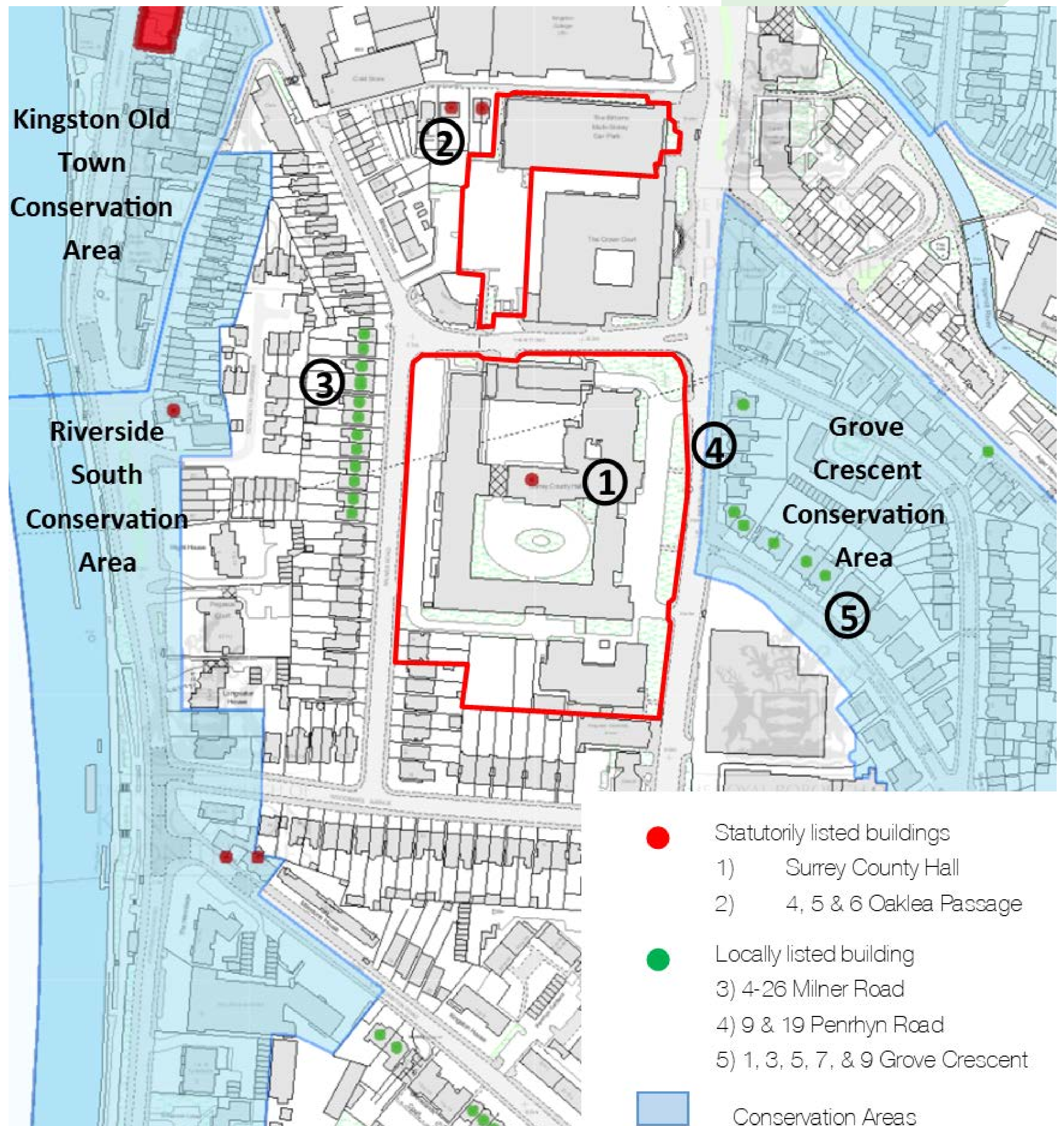

Proposed changes in response to Historic England